

# X80

## Xenon Beacon

**L G M**

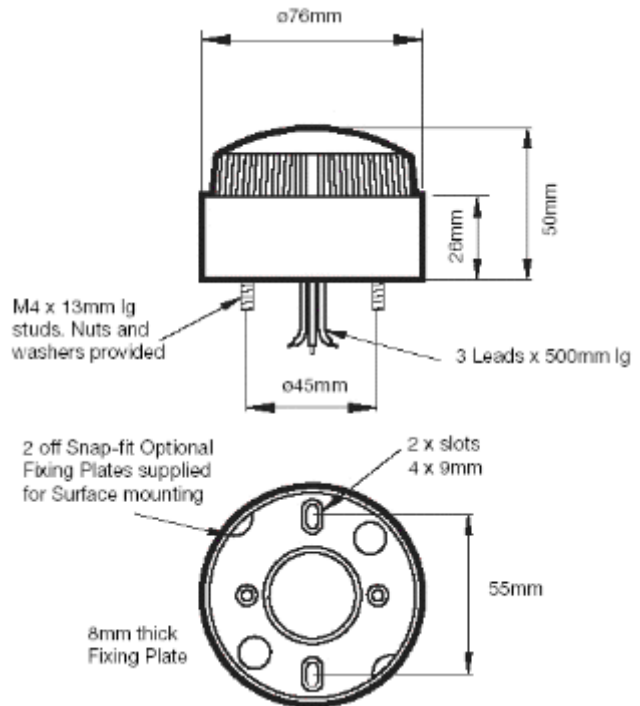

### SPECIFICATION

Model	Voltage	Flash energy	Current
X80-1	24Vdc	0.3J	40mA
X80-2	1-100Vdc 20-72Vac	1.0J	110mA @ 24vdc
X80-4	85-265Vac	2.0J	50mA @ 230Vac

<b>IP Rating</b>	67
<b>Flash Rate</b>	60/65 flashes per minute
<b>Weight</b>	0.13kg
<b>Op temp deg C</b>	-20°C to +55°C
<b>LED colour options</b>	Amber, Red, Blue, Green, Clear
<b>Base Colour</b>	Black
<b>Lens material</b>	UV Stable Polycarbonate
<b>Base Material</b>	UV Stable ABS
<b>Rating</b>	Continuous

**LGM PRODUCTS LTD**  
**UNIT 18 RIVERSIDE INDUSTRIAL ESTATE**  
**FARNHAM**  
**SURREY GU9 7UG**  
**UNITED KINGDOM**

**TEL 44 (0) 1252 725257**  
**FAX 44 (0) 1252 727627**  
**E-mail sales@Lgmproducts.com**