

X75

Xenon Beacon

L G M
PRODUCTS

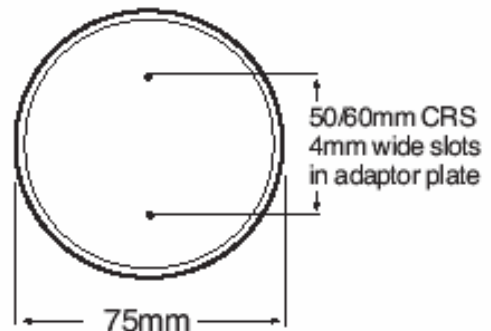
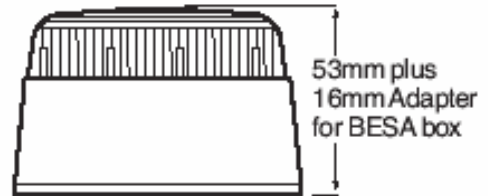

SPECIFICATION

| Voltage | Flash energy | Current |
|---------|--------------|---------|
| 24Vdc | 0.3J | 40mA |
| 115Vac | 1.0J | 35mA |
| 230Vac | 1.0J | 20mA |

| | |
|---------------------------|-----------------------------------|
| IP Rating | 65 |
| Flash Rate | 1Hz |
| Weight | 0.13kg |
| Op temp deg C | -20°C to +40°C |
| LED colour options | Amber, Red, Blue, Green, Clear |
| Base Colour | Black |
| Lens material | UV Stable Polycarbonate |
| Base Material | UV Stable ABS |
| Rating | Continuous |

ORDER CODE:

X75/Voltage/Lens Colour

LGM PRODUCTS LTD
UNIT 18 RIVERSIDE INDUSTRIAL ESTATE
FARNHAM
SURREY GU9 7UG
UNITED KINGDOM

TEL 44 (0) 1252 725257
FAX 44 (0) 1252 727627
E-mail sales@Lgmproducts.com
www.Lgmproducts.com