

X500 / 501 Xenon Beacon

L G M
PRODUCTS

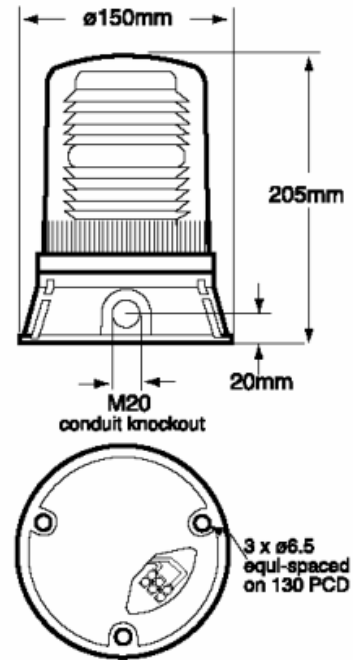

SPECIFICATION

Part No	Voltage	Flash Energy*		Current
		Single flash	Double flash	
X501	12Vdct	24J	18J	2.3A
X501	24 Vdct	24J	18J	1.3
X500	115Vac	24J	18J	0.65A
X500	230Vac	24J	18J	0.40A

IP Rating	65
Flash Rate	60 Hz(Single Flash) 90 Hz(Double Flash)

Weight	1.25 Kgs
Op temp deg C	-25°C to +35°C
Lens colour options	Amber, Red, Blue Green, Clear

Base Colour	Black
Lens material	UV Stable Polycarbonate
Base Material	UV Stable ABS
Rating	Continuous

SETTINGS

† 12Vdc and 24Vdc beacons are preset to 24Vdc at the factory but can be set on site to 12 Vdc operation by the end user.

* Units can be set to Single or Double Flash on site by the end user.

ORDER CODE:

X501/Voltage/Lens Colour

LGM PRODUCTS LTD
UNIT 18 RIVERSIDE INDUSTRIAL ESTATE
FARNHAM
SURREY GU9 7UG
UNITED KINGDOM

TEL 44 (0) 1252 725257
FAX 44 (0) 1252 727627
E-mail sales@Lgmproducts.com
www.Lgmproducts.com