

X201SD-200S

Xenon Beacon

L G M
PRODUCTS

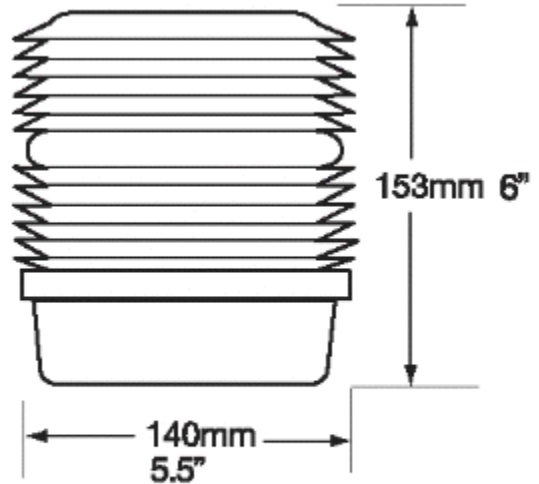

0.5" NPT Conduit Thread
2 x 0.2"Ø Drillout
Fixing Holes on 3.5" PCD

SPECIFICATION

| Model No | Voltage | Flash Energy | Current |
|-----------|----------|--------------|-------------|
| X201SD-12 | 12-48Vdc | 11J | 150mA@24Vdc |
| X200S-240 | 240Vac | 11J | 55mA |

| | |
|----------------------|---|
| IP Rating | 66 |
| Flash Rate | 120fpm (DC Version) 50fpm (AC Version) |
| Weight | 0.92 Kgs |
| Op temp °C | -35°C to +66°C |
| Lens colour | Amber, Red |
| options | |
| Base Colour | Black |
| Lens material | UV Stable Polycarbonate |
| Base Material | UV Stable ABS |
| Rating | Continuous |

ORDER CODE:

X201 Model Number/Lens Colour

LGM PRODUCTS LTD
UNIT 18 RIVERSIDE INDUSTRIAL ESTATE
FARNHAM
SURREY GU9 7UG
UNITED KINGDOM

TEL 44 (0) 1252 725257
FAX 44 (0) 1252 727627
E-mail sales@Lgmproducts.com
www.Lgmproducts.com