

X201-200

Xenon Beacon

L G M
PRODUCTS

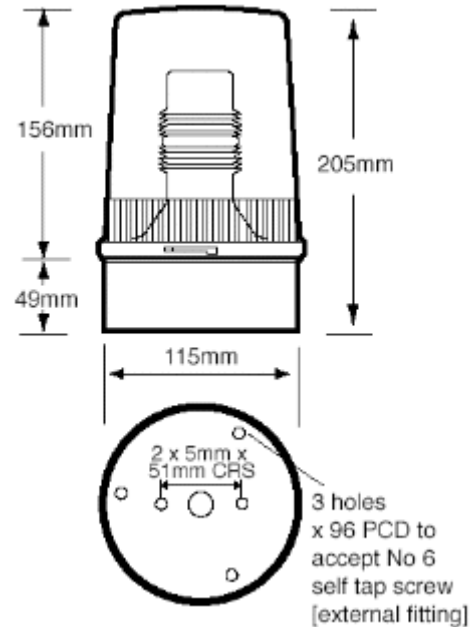

SPECIFICATION

Model No	Voltage	Flash Energy		Current
		Single	Double	
X201-18	12/24Vdc	10J	10J/7.5J	1.45mA
X201-19	12/24Vdc	10J	10J/7.5J	1.45mA
X200-88	24Vac	10J	10J/7.5J	0.72A
X200-21	115Vac	10J	10J/7.5J	0.10A
X200-22	230Vac	10J	10J/7.5J	0.06A

SETTINGS

-12Vdc and 24Vdc beacons are preset to 24Vdc at the factory but can be set on site to 12 Vdc operation by the end user.

-Units can be set to Single or Double Flash on site by the end user. For double Flash the first number is the flash energy of the first flash, the second number is the flash energy of the second.

-Model X201-19 beacons have a polarised diode.

ORDER CODE:

X201 Model Number/Lens Colour

LGM PRODUCTS LTD
UNIT 18 RIVERSIDE INDUSTRIAL ESTATE
FARNHAM
SURREY GU9 7UG
UNITED KINGDOM

IP Rating	65
Flash Rate	60 Hz(Single Flash) 90 Hz(Double Flash)
Weight	0.72 Kgs
Op temp °C	-25°C to +55°C
Lens colour	Amber, Red, Blue
options	Green, Clear
Base Colour	Black
Lens material	UV Stable Polycarbonate
Base Material	UV Stable ABS
Rating	Continuous

TEL 44 (0) 1252 725257
FAX 44 (0) 1252 727627
E-mail sales@Lgmproducts.com
www.Lgmproducts.com