

X125

Xenon Beacon

L G M
PRODUCTS

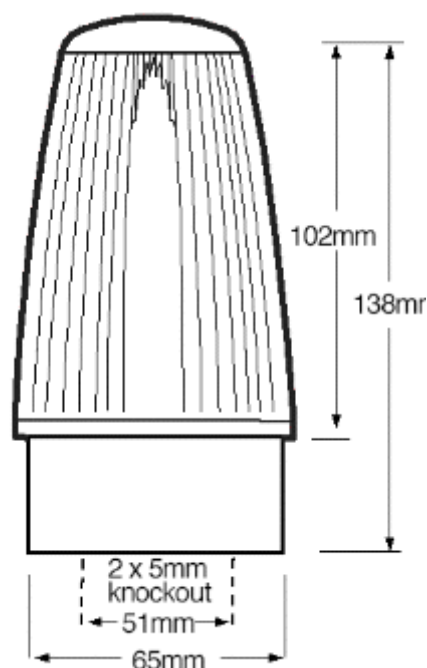

SPECIFICATION

Part No	Voltage	Flash Energy	Current	Mounting
X125-Ac/Dc	10-100Vdc 20-72Vac	2.0J	130mA @24Vdc	Surface/Wall
X125-55	115Vac	2.3J	30mA	Surface/Wall
X125-56	230Vac	2.7J	21mA	Surface/Wall
X125-64	10-100Vdc 20-72Vac	2.0J	130mA @24Vdc	DIN Base
X125-62	115Vac	2.3J	30mA	DIN Base
X125-63	230Vac	2.7J	21mA	DIN Base
X125ES-51	115Vac	2.3J	30mA	ES27 Screw
X125ES-52	230Vac	2.7J	21mA	ES27 Screw

IP Rating	65
Flash Rate	60 Hz
Weight	0.20kg
Op temp °C	-25°C to +55°C
Lens colour	Amber, Red, Blue
options	Green, Clear
Base Colour	Black
Lens material	UV Stable Polycarbonate
Base Material	UV Stable ABS
Rating	Continuous

ORDER CODE:
X125 Model/Lens Colour

LGM PRODUCTS LTD
UNIT 18 RIVERSIDE INDUSTRIAL ESTATE
FARNHAM
SURREY GU9 7UG
UNITED KINGDOM

TEL 44 (0) 1252 725257
FAX 44 (0) 1252 727627
E-mail sales@Lgmproducts.com
www.Lgmproducts.com