

Solista MAXI

LED Beacon

L G M
PRODUCTS

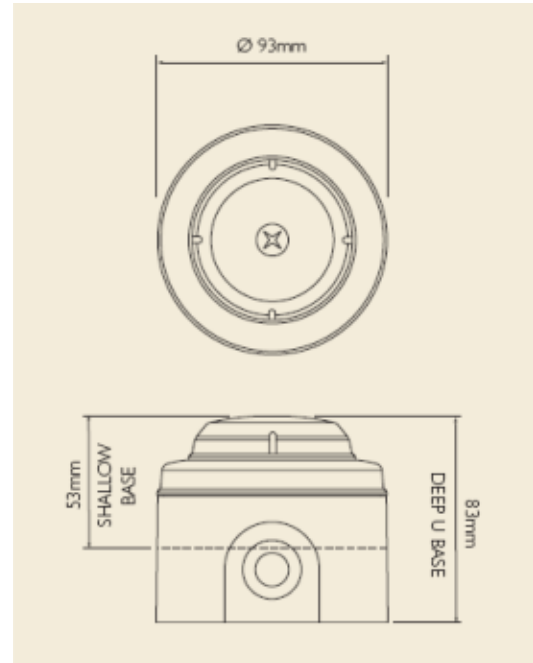

SPECIFICATION

Voltage Options	Flash rate	Flash intensity
9—60 Vdc*	1Hz single or double flash (selectable)	>0.5Cd @ 3mA >1.0Cd @ 6mA >3.0cd @ 15mA (selectable)

*110/230Vac when used with a Deep powered base

IP Rating	21 Shallow base 33 deep or U base
Cable entry	M20 knockouts (Deep Base & U Base) Rear entry BESA box (Shallow Base)
Op temp deg C	-10 to +55°C
Body Material	ABS body, polycarbonate lens
Body Colour	Red or White
LED colour	Red, Amber, White
Base options	Shallow, deep, "U"
Operation	Continuous
Monitoring	Reverse Polarity
Weight	0.1kg

ORDER CODE: SolistaMAXI/Base type/Base colour/LED Colour

LGM PRODUCTS LTD
UNIT 18 RIVERSIDE INDUSTRIAL ESTATE
FARNHAM
SURREY GU9 7UG
UNITED KINGDOM

TEL +44 (0) 1252 725257
FAX +44 (0) 1252 727627
E-mail sales@Lgmproducts.com
www.Lgmproducts.com