

MTL 7700 series

Shunt-diode safety barriers

L G M
PRODUCTS

HOW THEY WORK

All MTL7700 Series barriers are based on the same simple principle. Each channel contains two stages of pulse-tested Zener or forward connected diodes and an 'infallible' terminating resistor. In the event of an electrical fault in the safe area, the diodes limit the voltage that can reach the hazardous area and the resistor limits the current. A fuse protects the diodes, and the two stages of voltage limitation ensure continued safety if either stage should fail. No active output current limiting circuits are employed. All models are certified 'ia' for all zones and 'IIC' for all explosive atmospheres (except MTL7707P+ and MTL7729P+, 'ia' 'IIB').

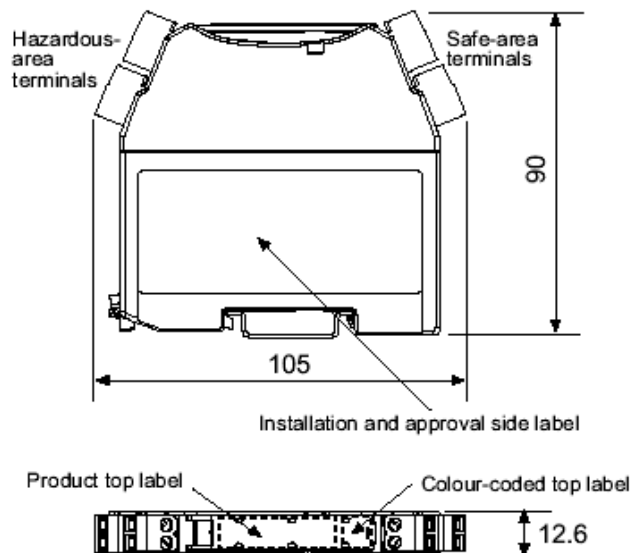

TERMINOLOGY

1. Safety description

The safety description of a barrier, eg '10V 50&200mA', refers to the maximum voltage of the terminating Zener or forward diode while the fuse is blowing, the minimum value of the terminating resistor, and the corresponding maximum short-circuit current. It is an indication of the fault energy that can be developed in the hazardous area, and not of the working voltage or end-to-end resistance.

2. Polarity

Barriers may be polarised + or -, or non-polarised ('ac'). Polarised barriers accept and/or deliver safe-area voltages of the specified polarity only. Non-polarised barriers support voltages of either polarity applied at either end.

3. End-to-end resistance

The resistance between the two ends of a barrier channel at 20°C, ie of the resistors and the fuse. If diodes or transistors are present, their voltage drop (transistors ON) is quoted in addition.

4. Working voltage (Vwkg)

The greatest steady voltage, of appropriate polarity, that can be applied between the safe-area terminal of a 'basic' barrier channel and earth at 20°C for the specified leakage current, with the hazardous-area terminal open circuit.

5. Maximum voltage (Vmax)

The greatest steady voltage, of appropriate polarity, that can be applied continuously between the safe-area terminal of any barrier channel and earth at 20°C without blowing the fuse. For 'basic' barriers, it is specified with the hazardous-area terminal open circuit; if current is drawn in the hazardous area, the maximum voltage for these barriers is reduced. The 'ac' channels of 'basic' barriers and most channels of overvoltage-protected barriers withstand voltages of the opposite polarity also – see circuit diagrams.

6. Fuse rating

The greatest current that can be passed continuously (for 1000 hours at 35°C) through the fuse.

7. Maximum safe-area voltage (Um)

The maximum permissible safe-area voltage (Um) for MTL7700 Series barriers is 250V ac/dc.

GENERAL SPECIFICATION

Ambient temperature and humidity limits

-20 to +60°C continuous working

-40 to +80°C storage

5-95% RH

Leakage current

For 'basic' barriers with a working voltage of 5V or more, the leakage current decreases by at least one decade per volt reduction in applied voltage below the working voltage, over two decades. For the MTL7755ac/7756ac it decreases by at least one decade for a 0.4V reduction in applied voltage.

Terminations

Removable terminals accommodate conductors up to 2.5mm² (13AWG). Hazardous-area terminals are identified by blue labels. Removal force >15N

Colour coding of barrier label

Grey: non-polarised

Red: positive polarity (MTL7706 negative to transmitter)

Black: negative polarity

White: dummy barrier, MTL7799

Weight

140g approx

Mounting and earthing

By 35mm Top Hat DIN rail

KEY MTL7700 SERIES BARRIERS

7756ac Resistance temperature detectors

7760ac Thermocouples, ac sensors

7728+ Controller outputs, one line earthed

7787 +Controller outputs, neither line earthed

7706+ & 7787+ Transmitters, 2-wire, 4/20mA

7787+ & 7741/3 Switches

7728 Solenoids, alarms, LEDs

SEE PAGE 2 FOR DETAILED SPECIFICATIONS OF EACH BARRIER

LGM PRODUCTS LTD
UNIT 18 RIVERSIDE INDUSTRIAL ESTATE
FARNHAM
SURREY GU9 7UG
UNITED KINGDOM

TEL +44 (0) 1252 725257
FAX +44 (0) 1252 727627
E-mail Sales@Lgmproducts.com
www.Lgmproducts.com

DETAILED SPECIFICATIONS
 'Key' barriers shown in blue

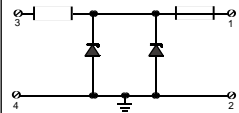
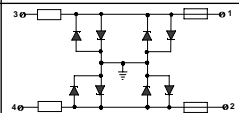
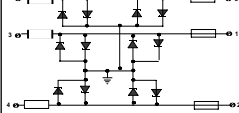
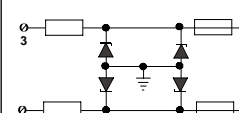
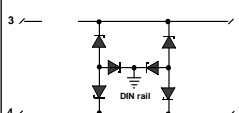
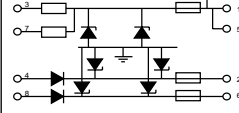
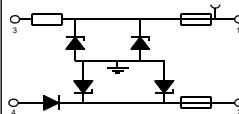
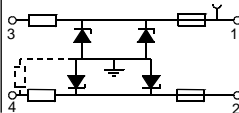
Model No.	Safety description			Polarities available			Application	Basic circuit		Max. end-to-end resistance Ω	Vwkg at 10 (1)μA V	Vmax V	Fuse rating mA
	MTL	V	Ω	mA	+	-		ac	Hazardous				
7706+ 7707+	28 28	300 300	93 93	√ √			Transmitters Switches	See 'HOW THEY WORK' and 'ACTIVE / ELECTRONICALLY PROTECTED BARRIERS'		See additional specification		35 35 35	50 50 50
7707P+	28 28	164 diode	171 -	√									
7710+ 7715+ 7715P+ 7722+ 7728+ 7728- 7728ac 7728P+ 7729P+	10 15 15 22 28 28 28 28	50 100 50 150 300 300 234	200 150 291 147 93 93 119 170	√ √ √ √ √ √ √ √		√	6V dc & 4V ac systems 12V systems 12V dc systems 18V dc systems Controller outputs, solenoids Transmitters Controller outputs, solenoid valves Controller outputs, solenoid valves IIB		75 119 64 174 333 333 252 184	6.0 12.0 12.6 19.6 25.9 25.0 24.9 24.9	7.0 13.1 13.7 20.2 26.5 26.5 24.9 25.9 25.9	50 100 100 50 50 50 100 100	
774X	10	—	19				Prox sw input, solid state output and line fault detect	See 'ACTIVE / ELECTRONICALLY PROTECTED BARRIERS'	—	—	30/35	50	
7755ac	3 3	10 10	300 300			√ √	2 or 3- Wire (floating) RTDs		19.0 19.0	(1) (1)	3.4 3.4	250 250	
7756ac	3 3 3	10 10 10	300 300 300			√ √ √	3 - Wire (grounded) RTDs		19.0 19.0 19.0	(0.7) (0.7) (0.7)	2.7 2.7 2.7	250 250 250	
7758+/- 7761ac 7761Pac 7764+ac 7766ac 7766Pac 7767+ 7779+ 7796+ 7796-	7.5 9 9 9 12 12 12 15 15 28 28 26 20 20	10 90 90 350 1k 150 75 100 100 300 300 300 390 300	750 100 100 26 26 12 80 157 150 150 93 93 87 51 87 51	√ √ √ √ √ √ √ √ √ √ √ √ √ √	√ √ √ √ √ √ √ √ √ √ √ √ √ √		Gas detectors Strain-gauge bridges Strain-gauge bridges Strain-gauge bridges Strain-gauge bridges Strain-gauge bridges 12V dc systems 12V dc systems Controller outputs Controller outputs Vibration probes Vibration probes		17 107 107 378 1050 1050 174 174 92 92 119 119 333 333 333 428 333 428	6.0 6.0 6.0 6.8 10.0 10.0 10.0 10.0 9.6 9.6 12.0 12.0 25.9 25.9 23.9 18.3 23.9 18.3	7.3 7.0 7.0 7.5 10.9 10.6 10.6 10.5 10.5 13.1 13.1 26.5 26.5 24.5 18.9 24.5 18.9	100 100 100 50 50 50 50 100 100 50 50 50 50 50 50 50 50	
7760ac 7765ac 7778ac	10 10 15 15 28 28	50 50 100 100 600 600	200 200 150 150 47 47			√ √ √	Active dc & ac sensors Thermocouples		75 75 124 124 651 651	6.0 6.0 12.0 12.0 0.4 0.4	6.7 6.7 12.5 12.5 0.4 0.4	50 50 50 50 50 50	
7789+	28 28 28	300 diode diode	93 ^a — —	√			Switch inputs / Signal returns		651 651 0.9V+26Ω 0.9V+26Ω	26.6 26.6 26.6 26.6	27.2 27.2 27.2 27.2	50 50 50 50	
7787+ 7787P+	28 28	300 diode	93 —	√			Transmitters Controller outputs, switches Transmitters, Controller outputs, switches		333 0.9V+26Ω 253 0.9V+21Ω	26.6 26.6 26.4 26.4	27.2 27.2 27.2 27.2	50 50 80 80	
7788+ 7788R+	28 10 28 10	300 50 300 50	93 200 93 200	√ √ √ √			Transmitters		333 75 333 75	25.9 6.0 25.9 —	26.5 7.0 26.5 7.0	50 50 50 50	

a Terminals 3 & 7 connected together
 *Diagrams show positive versions. All diodes reversed on negative versions. Additional diodes fitted on ac versions.