

# MB005

## Xenon Beacon

**L G M**  
**PRODUCTS**

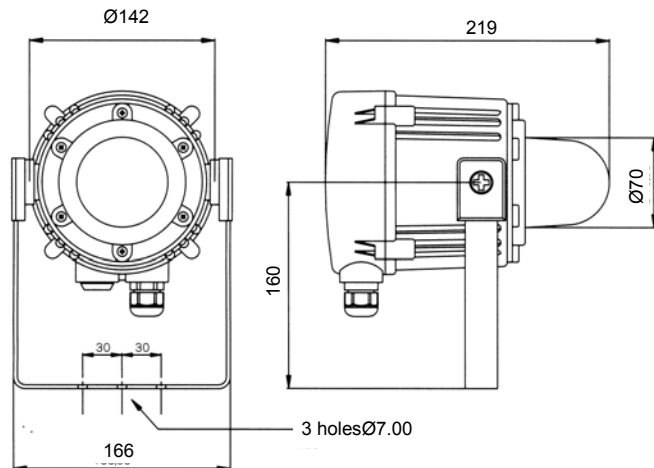

### SPECIFICATION

Voltage Options	Voltage Tolerance	Flash energy	Current mA	Weight Kg.		
230 Vac	+/- 10%	5.0	55 mA	2.5	<b>IP Rating</b>	67
115 Vac	+/- 10%	5.0	140 mA	2.5	<b>Flash Rate</b>	1 Hz
48 Vdc	42-54vdc	5.0	180 mA	2.25	<b>Max RH</b>	90% at 20 °C
24 Vdc	20-28vdc	5.0	300 mA	2.25	<b>Storage Temp</b>	-40 to +70 °C
12 Vdc	10-14vdc	5.0	550 mA	2.25	<b>Op Temp</b>	-25 to +55 °C
					<b>Lens colour options</b>	Red, Amber, Green, Blue, Yellow, Clear
					<b>Base Colour options</b>	Grey (RAL7038)
					<b>Terminal capacity</b>	4.0 mm <sup>2</sup>
					<b>Cable Entry</b>	2x M20 Gland Entries
					<b>Lens Material</b>	Glass
					<b>Base Material</b>	UL94V0 ABS

**ORDER CODE:**  
MB005/voltage/lens colour

**LGM PRODUCTS LTD**  
**UNIT 18 RIVERSIDE INDUSTRIAL ESTATE**  
**FARNHAM**  
**SURREY GU9 7UG**  
**UNITED KINGDOM**

**TEL 44 (0) 1252 725257**  
**FAX 44 (0) 1252 727627**  
**E-mail Lgminternational@btinternet.com**  
**www.lgmproducts.com**