

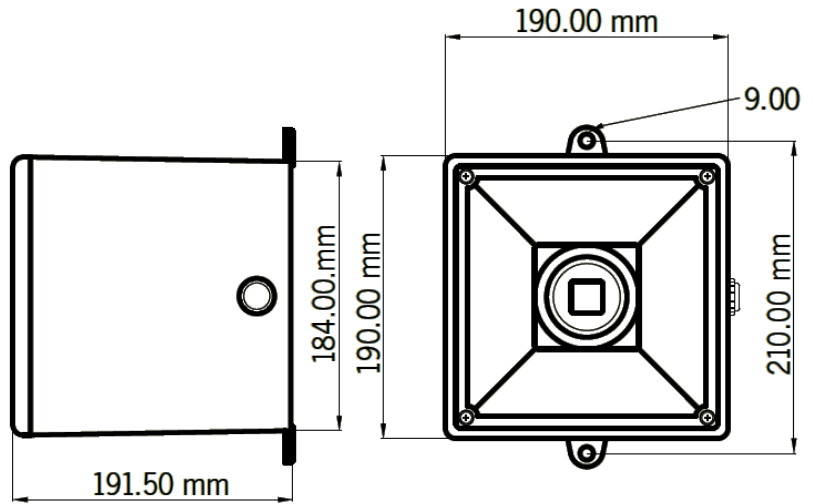

- Output: 126dB(A)
- 5 Tone, 3 Stages
- IP Rating: 66
- Available Voltages: 24Vdc
115Vac 230Vac

Max. sound output	121dB
Nominal sound output	121dB
IP rating	66
Alarm tones	5
Alarm stages	3
Volume control	available
Cable entry	2 x M20
Terminal capacity	0.5 to 4.0mm ² cables
Max. RH	90% at 20°C
Operating temp.	-25°C to +55°C
Storage temp.	-40°C to +70°C
Body material	Flame Retardant ABS
Colour options	Grey, Red
Unit weight	2.10Kg (DC) 2.70Kg (AC)



Approvals:

GOST-R approved. Cert: POCC GB-JB05-B02225

Voltage options	Voltage tolerance	Current
24 Vdc	10 to 30 Vdc	375mA
115 Vac	+/- 10%	160mA
230 Vac	+/- 10%	75mA

HA121 Sound Output

Tone No.	Sound Description	dB @ 1m
1	Industrial Hooter	115dB
2	High Frequency Mechanical Siren	119dB
3	Medium Frequency Mechanical Siren	121dB
4	Electro Mechanical Buzzer	119dB
5	Mechanical Bell	113dB