

# Flashni Combined Sounder and Beacon

**L G M**  
**PRODUCTS**

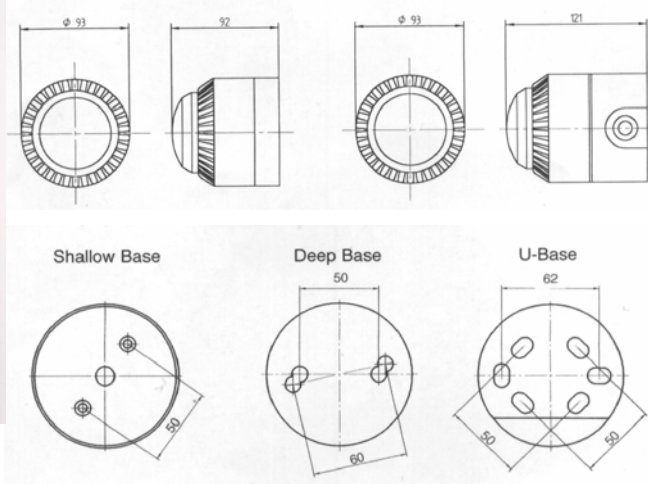

Flashni with deep base



<b>Voltage Options</b>	<b>Voltage tolerance</b>	<b>Current mA*</b>	<b>Weight Kg.</b>	<b>Flash Energy</b>	<b>Sound output *</b>	101dB(A)
24 Vdc	18-30Vdc	68	0.4	0.7Joules	<b>Flash Rate</b>	1 Hertz
12 Vdc	9-15 Vdc	110	0.4	0.7 Jpules	<b>IP Rating</b>	
					Deep & U Base	65
					Shallow base	54
					<b>Alarm tones</b>	2 or 32*
					<b>Alarm Stages</b>	2
					<b>Volume Control</b>	Yes
					<b>Cable entry</b>	M20 Knockouts
					<b>Terminal Capacity</b>	2 in 2 out 1 x 2.5mm
					<b>Op temp deg C</b>	-10 deg C to +55 deg C
					<b>Body Material</b>	ABS
					<b>Lens Material</b>	Polycarbonate plastic
					<b>Lens colour options</b>	Amber, blue, clear green, red

**\*NOTE:** Sound output and current consumption values are based on the 800 to 1000 Hz alternating signal, the standard UK fire alarm tone. These values will vary for other alarm tones

**ORDER CODE:** FL/Voltage /Lens colour/32tone\*

\*optional

**LGM PRODUCTS LTD**  
**UNIT 18 RIVERSIDE INDUSTRIAL ESTATE**  
**FARNHAM**  
**SURREY GU9 7UG**  
**UNITED KINGDOM**

**TEL +44 (0) 1252 725257**  
**FAX +44 (0) 1252 727627**  
**E-mail sales@Lgmproducts.com**  
**www.Lgmproducts.com**