

EXD BELL

Hazardous Area Bell

L G M
PRODUCTS

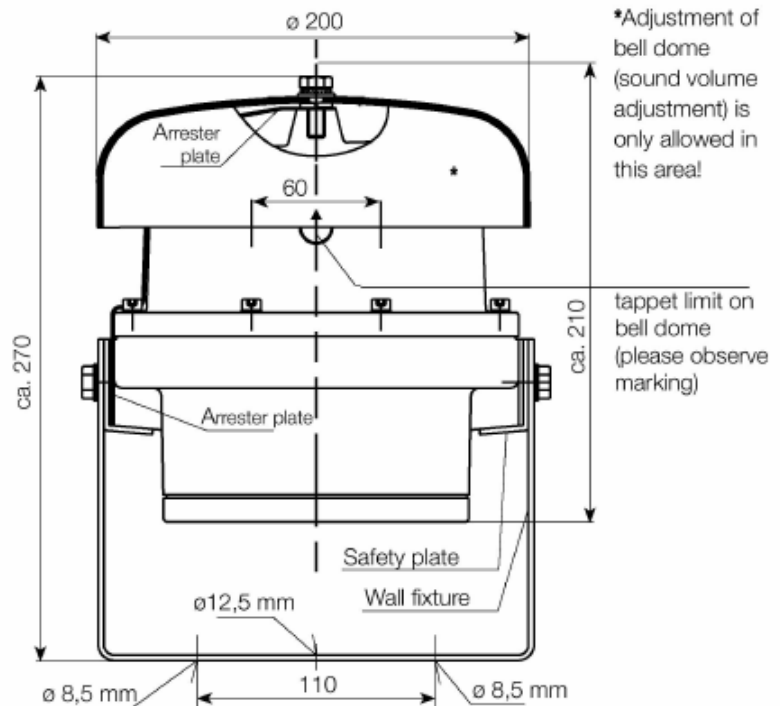
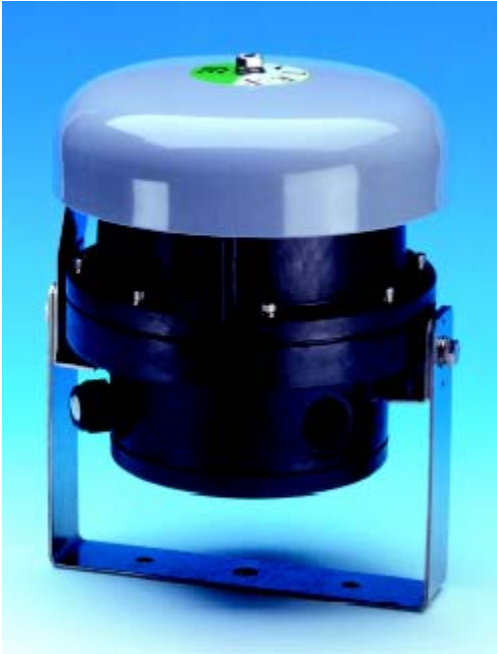

SPECIFICATION

Voltage Options	Voltage tolerance	Current mA	Weight Kg.
230 Vac	+/- 10%	60 mA	3.5
110 Vac	+/- 10%	140 mA	3.5
24 Vdc	+/- 10%	320 mA	3.5

Approvals:
ATEX approved
ex IIG EExde IIC T6

Sound output	105 db
IP Rating	IP66
Cable entry	1 x M20 & 1 x plugged M20
Operating Temp	-20 to +40 °C
Dome Material	Steel
Dome Colour	Grey
Body Material	Glass fibre reinforced polyester
Body Colour	Black
Duty Rating	Continuous
Frequency	1000 Hz

ORDER CODE:
EXD Bell/Voltage

LGM PRODUCTS LTD
UNIT 18 RIVERSIDE INDUSTRIAL ESTATE
FARNHAM
SURREY GU9 7UG
UNITED KINGDOM

TEL +44 (0) 1252 725257
FAX +44 (0) 1252 727627
E-mail Sales@Lgmproducts.com
www.Lgmproducts.com