

B400

Xenon Strobe Beacon

L G M
PRODUCTS

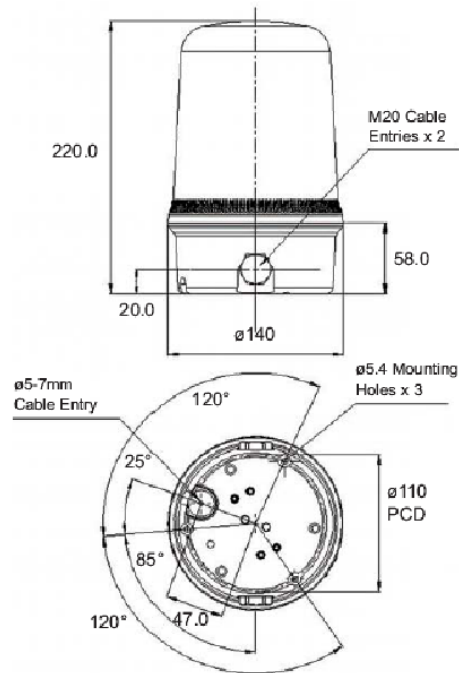
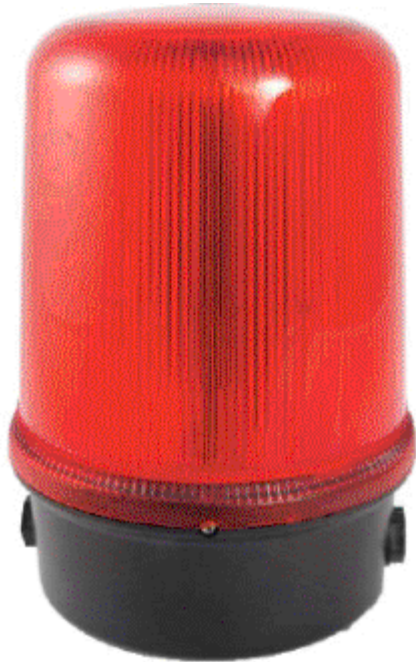

All dimensions in mm.

SPECIFICATION

Voltage	Current	Weight
24Vdc/ac	870mA	696g
48Vdc/ac	480mA	696g
115Vac	400mA	632g
230Vac	225mA	632g
Flash Pattern	Joules	Flash Rate
Double Flash	15 + 10	0.75Hz
Single Flash	15J	1Hz
Triple Flash	15 + 10 + 10	0.5Hz

IP Rating	65
Lens Type	Prismatic, Plain
Op temp deg C	-25°C to +50°C
Lens colours	Amber, Red, Blue Green, Clear, Yellow
Base Colour	Black
Lens material	UV Stable Polycarbonate
Base Material	UV Stable ABS
Rating	Continuous
Cable Entry	2 x M20, 1 x 5-7mm push through grommet
Mounting	Surface mount (bracket & pole mount accessories)

LGM PRODUCTS LTD
UNIT 18 RIVERSIDE INDUSTRIAL ESTATE
FARNHAM

TEL 44 (0) 1252 725257
FAX 44 (0) 1252 727627