

B300

Xenon Strobe Beacon

L G M
PRODUCTS

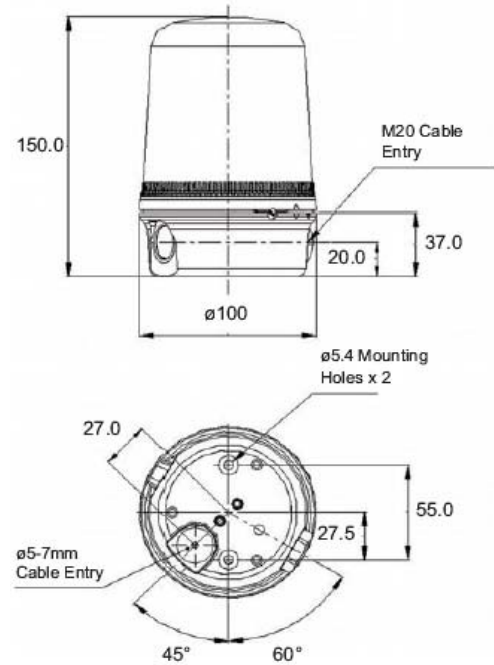

SPECIFICATION

Voltage	Current	Weight
12Vdc/ac	500/600mA	325g
24Vdc/ac	250/300mA	325g
48Vdc/ac	175/250mA	325g
115Vac	70mA	300g
230Vac	35mA	300g

IP Rating	65
Light Output	5 Joules @ 1Hz
Lens Type	Prismatic, Plain
Op temp deg C	-25°C to +50°C
Lens colours	Amber, Red, Blue Green, Clear, Yellow
Base Colour	Black
Lens material	UV Stable Polycarbonate
Base Material	UV Stable ABS
Rating	Continuous
Cable Entry	2 x M20, 1 x 5-7mm push through grom- met
Mounting	Surface mount (bracket & pole mount accessories)

ORDER CODE:
B300STR/Voltage/Lens Colour

LGM PRODUCTS LTD
UNIT 18 RIVERSIDE INDUSTRIAL ESTATE
FARNHAM
SURREY GU9 7UG
UNITED KINGDOM

TEL 44 (0) 1252 725257
FAX 44 (0) 1252 727627
E-mail sales@Lgmproducts.com
www.Lgmproducts.com