

A112N sounder

DC & AC Versions

L G M
PRODUCTS

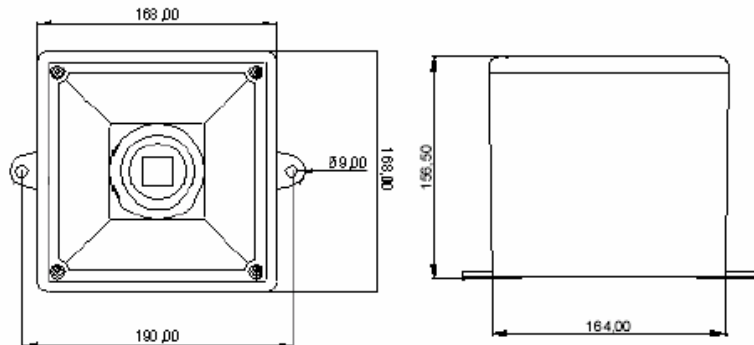

SPECIFICATION

Voltage Options	Voltage tolerance	Current mA*	Weight Kg.	Sound output *	112dB
230 Vac	+/- 10%	60mA	2.1	IP Rating	55
115 Vac	+/- 10%	110mA	2.1	IP Rating WR version	66
24 Vac	+/- 10%	500mA	2.1	Alarm tones	45
48Vdc	36 to 60	120mA	1.8	Alarm Stages	3
24Vdc	10 to 30	200mA	1.8	Volume Control	yes
				Cable entry	M20 knockouts
				Terminal Capacity	2 x 2.5 mm ²
				max RH	95% at 40 deg C
				Op temp deg C	-25 to +55°C
				Storage temp deg C	-40 to +75°C
				Body Material	ABS

***NOTE:** Sound output and current consumption values are based on the 800 to 1000 Hz alternating signal, the standard UK fire alarm tone. These values will vary for other alarm tones

APPROVALS: UL America approved version available

ORDER CODE:

A112N/Voltage /WR version*/UL*
*optional

LGM PRODUCTS LTD
UNIT 18 RIVERSIDE INDUSTRIAL ESTATE
FARNHAM
SURREY GU9 7UG
UNITED KINGDOM

TEL +44 (0) 1252 725257
FAX +44 (0) 1252 727627
E-mail Sales@Lgmproducts.com
www.Lgmproducts.com